

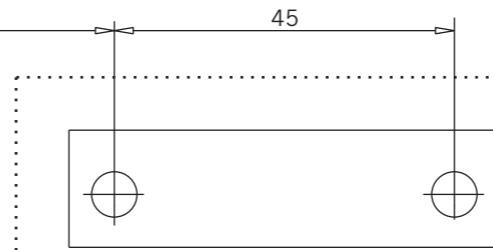

Papiersablonen können sich durch Luftfeuchtigkeit verändern. Verbindlich sind daher nur die Maßangaben.
Paper templates might distort due to air moisture. Only the indicated measurements are therefore obligatory.
Les gabarits en papier peuvent avoir des dimensions modifiées par l'humidité de l'air. Seules les côtes mentionnées doivent être respectées.

	ECO Schulte GmbH & Co.KG Iserlohner Landstraße 117 D-58706 Menden	04											
	0432-CPD-0029 EN 1154:1996+A1:2002	<table border="1"> <tr> <td>4</td> <td>8</td> <td>2-5</td> <td>1</td> <td>1</td> <td>4</td> </tr> <tr> <td>3</td> <td>8</td> <td>2-5</td> <td>1</td> <td>1</td> <td>4</td> </tr> </table>	4	8	2-5	1	1	4	3	8	2-5	1	1
4	8	2-5	1	1	4								
3	8	2-5	1	1	4								



- D** Nur für Größe 5 bohren
- GB** Drilling for size 5 only
- F** Percer seulement pour force 5

DIN links / left / gauche

- D** An der Oberkante der Tür anlegen
- GB** Set to top of door
- F** Haut de la porte
- D** Bandbezugslinie
- GB** Reference line for hinge
- F** Ligne référence de paumelle

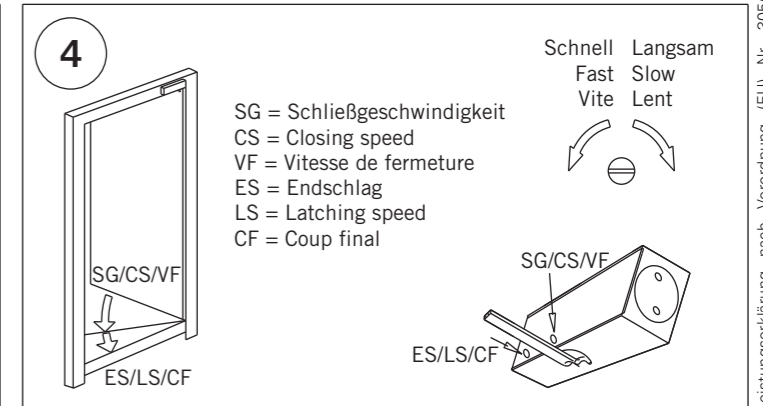
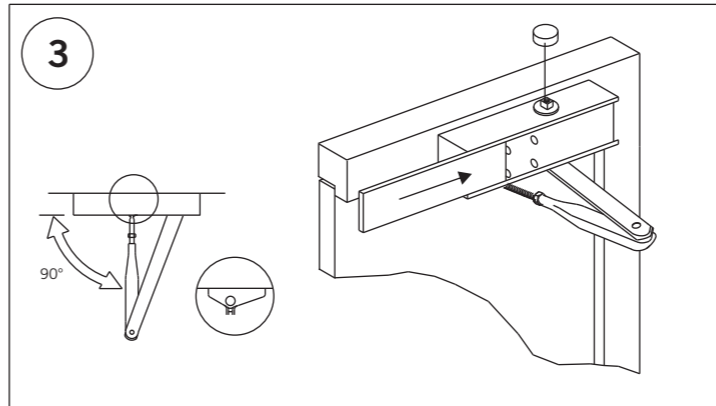
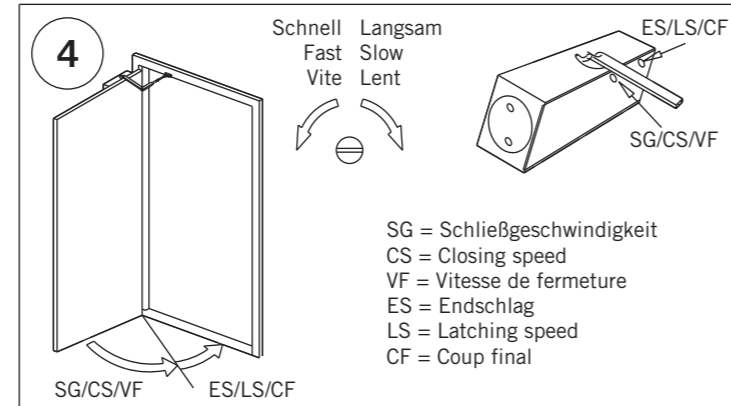
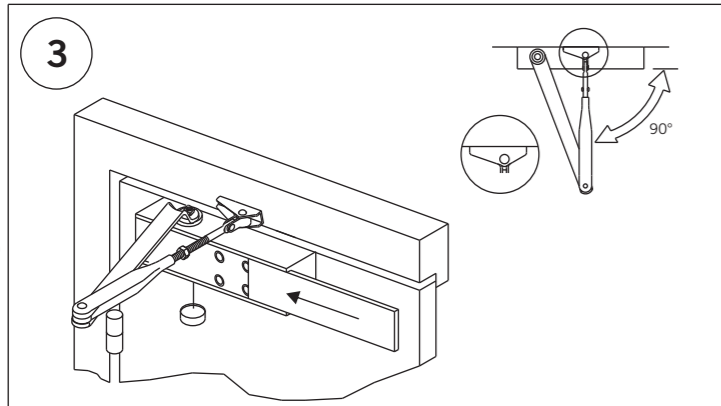
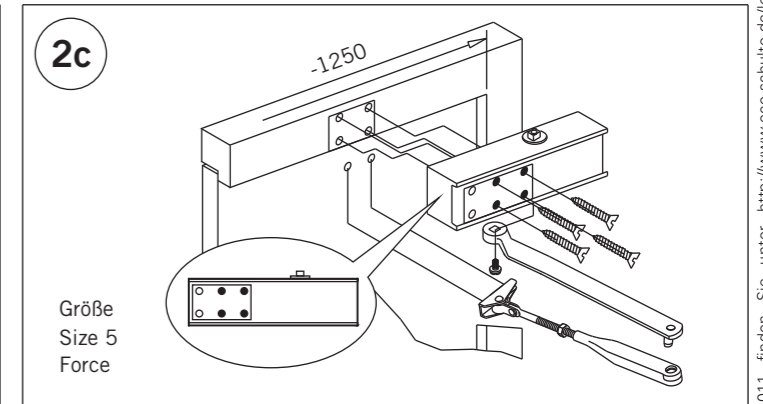
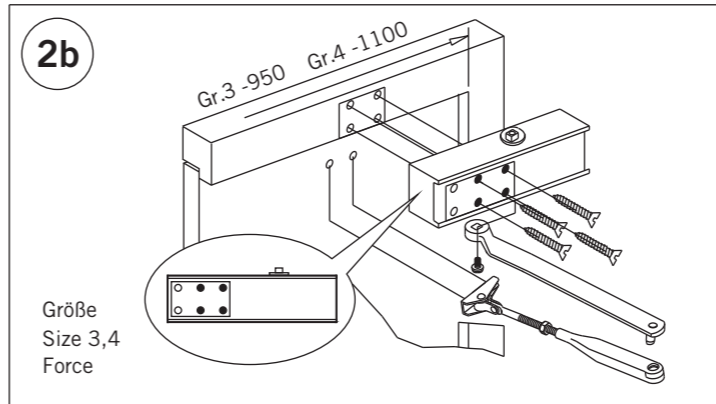
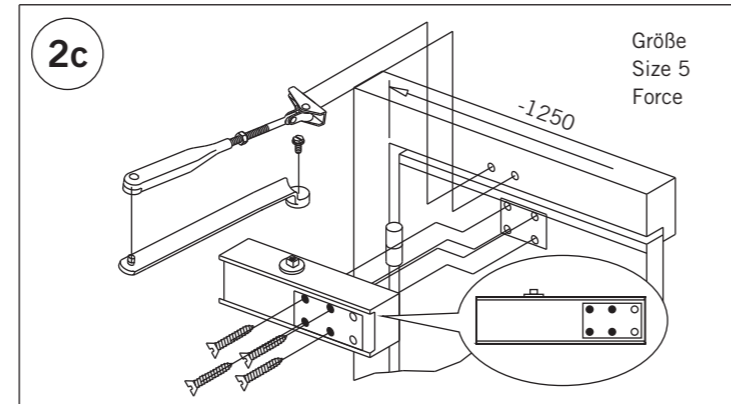
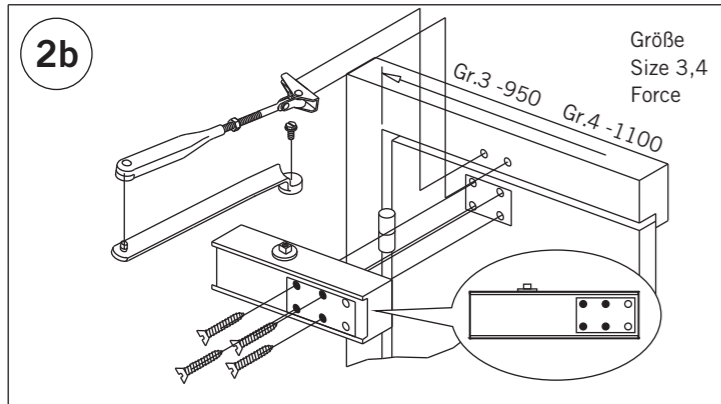
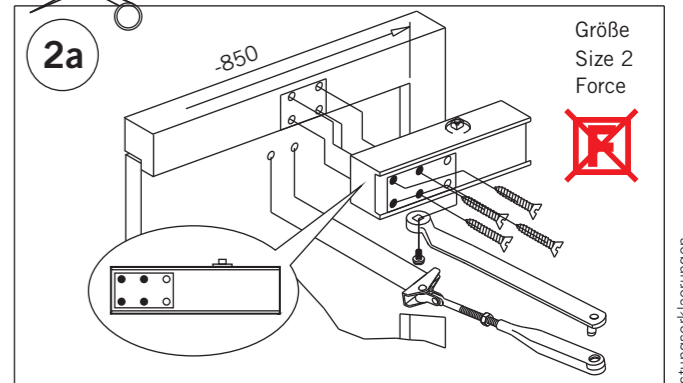
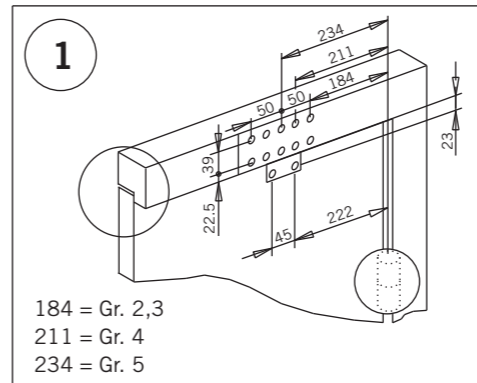
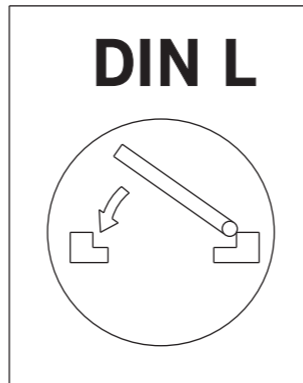
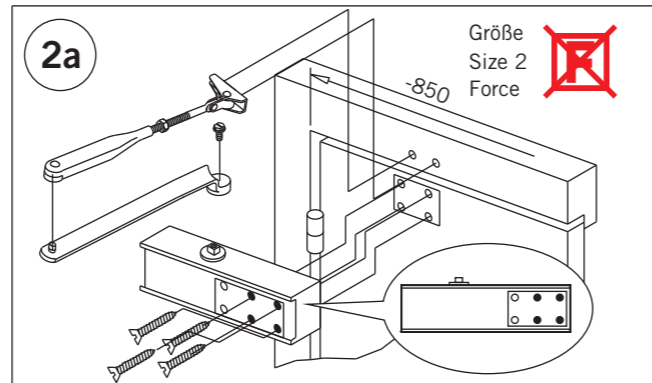
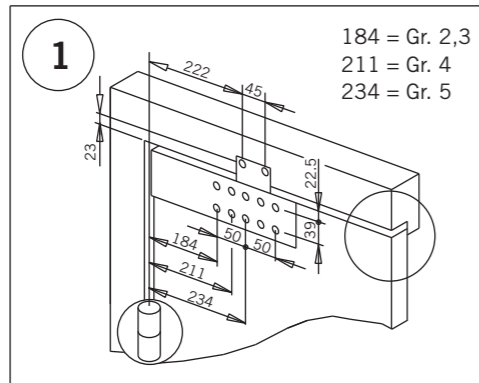
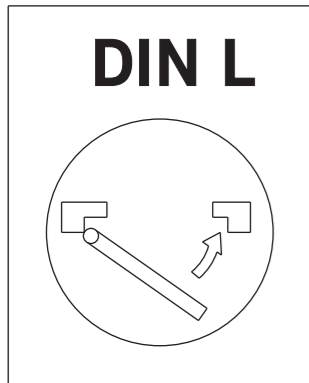
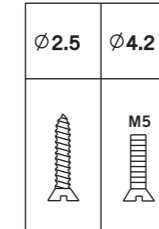
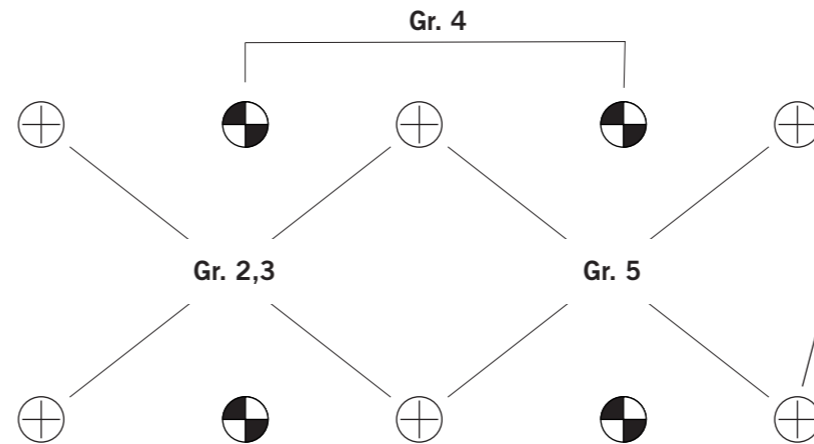
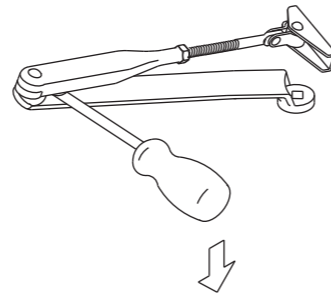
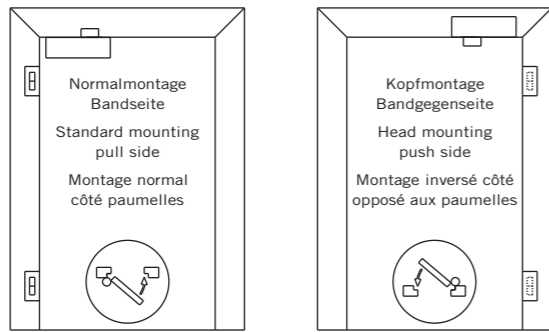

ECO TS-11 F

- D** Nur für Größe 5 bohren
- GB** Drilling for size 5 only
- F** Percer seulement pour force 5

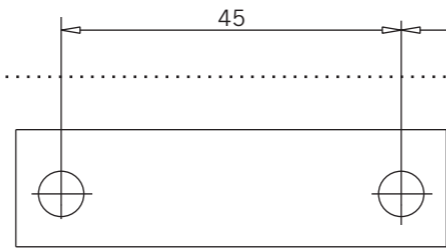

CE	ECO Schulte GmbH & Co.KG Iserlohner Landstraße 117 D-58706 Menden	04			
		4 3	8 8	2-5 2-5	1 1
0432-CPD-0029	EN 1154:1996+A1:2002				



Papierschablonen können sich durch Luftfeuchtigkeit verändern. Verbindlich sind daher nur die Maßangaben.
Paper templates might distort due to air moisture. Only the indicated measurements are therefore obligatory.
Les gabarits en papier peuvent avoir des dimensions modifiées par l'humidité de l'air. Seules les côtes mentionnées doivent être respectées.

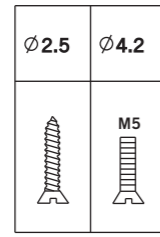
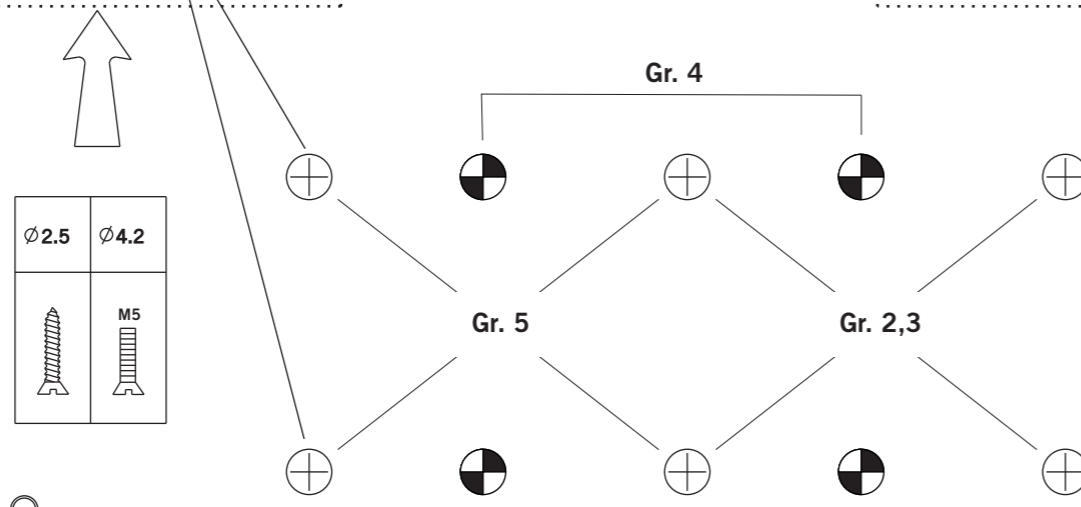

DIN rechts / right / droit

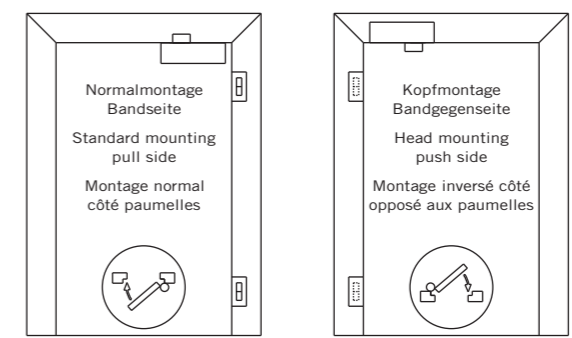

- D** An der Oberkante der Tür anlegen
- GB** Set to top of door
- F** Haut de la porte
- D** Bandbezugslinie
- GB** Reference line for hinge
- F** Ligne référence de paumelle

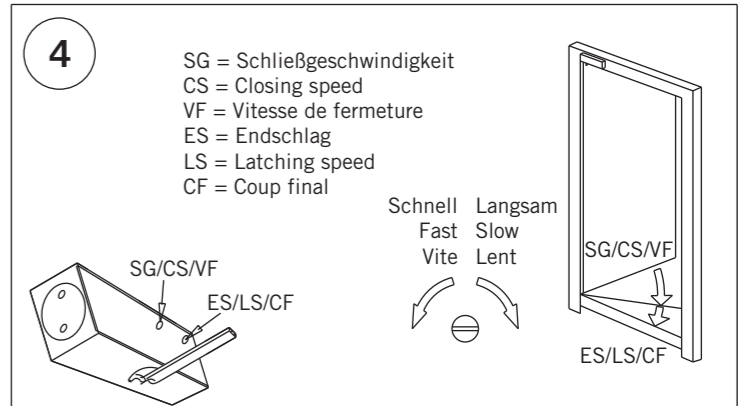
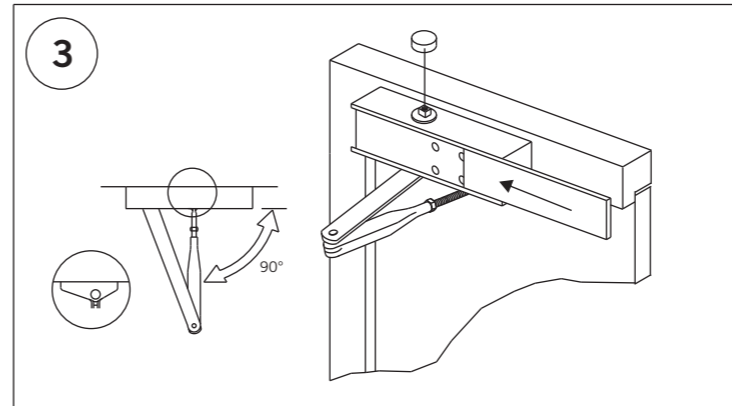
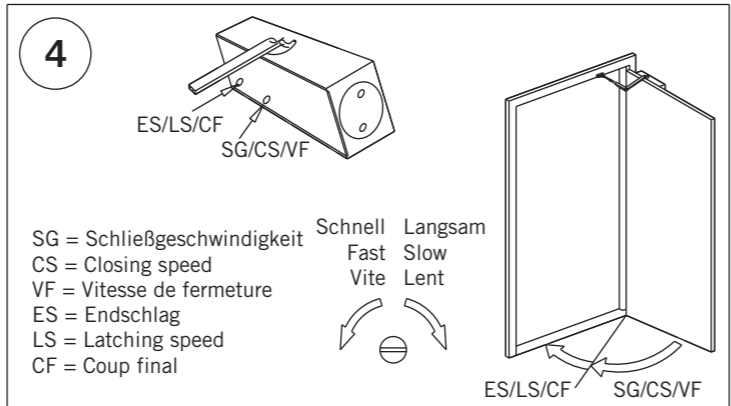
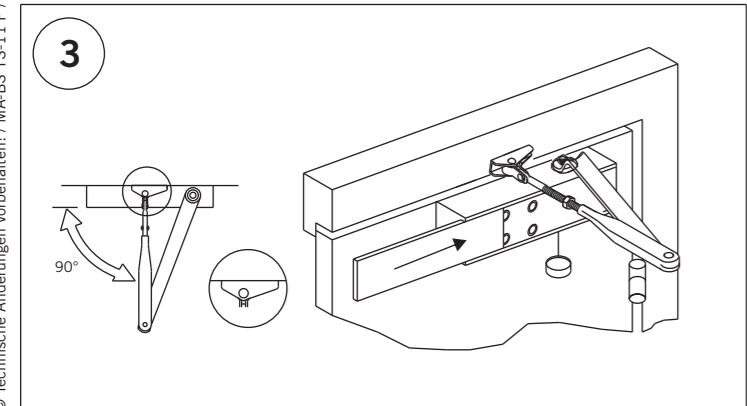
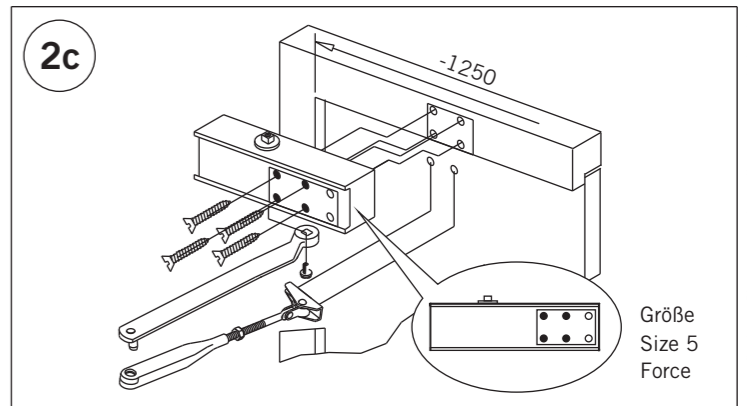
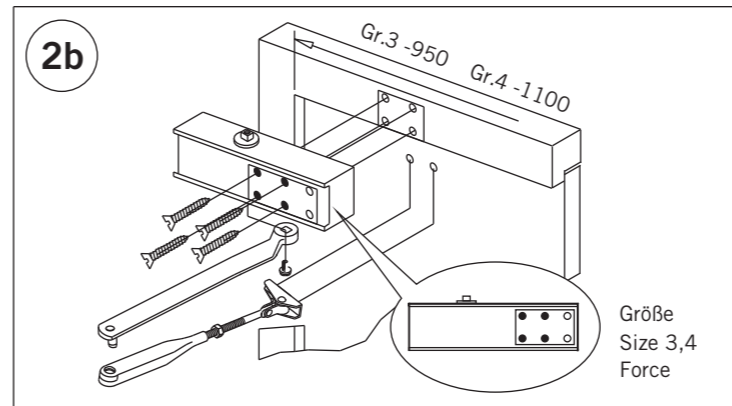
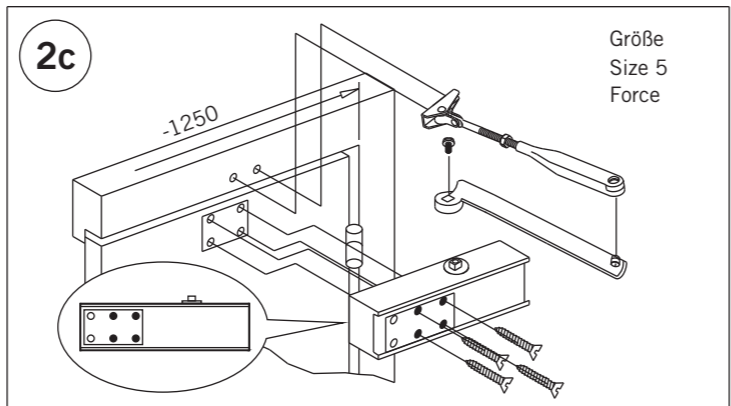
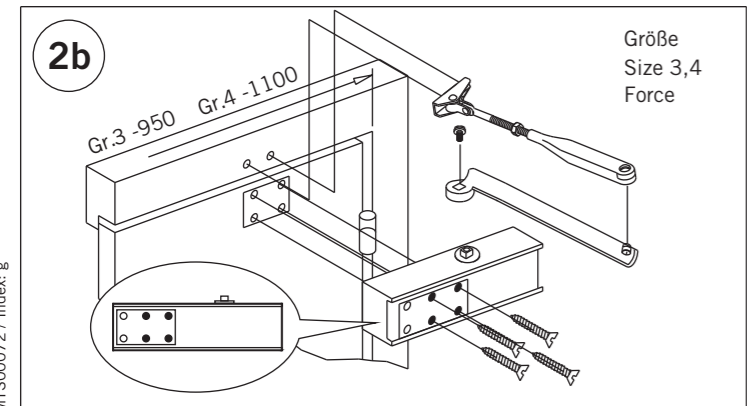
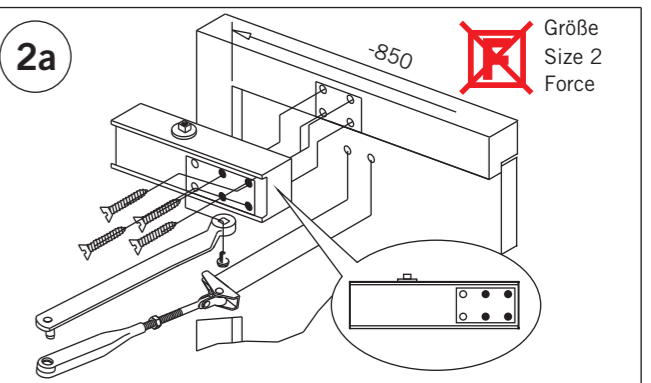
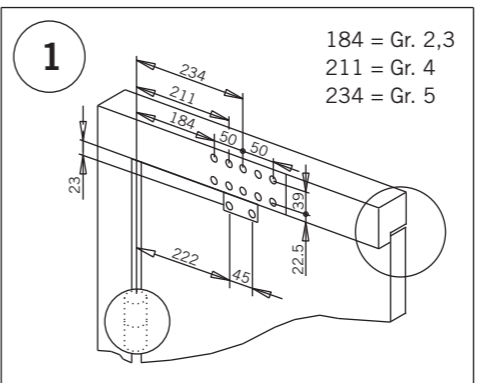
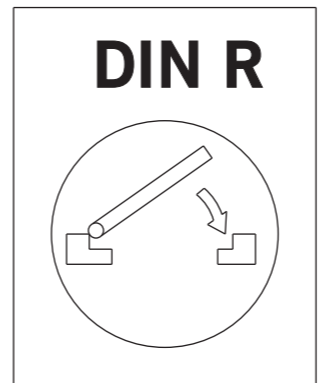
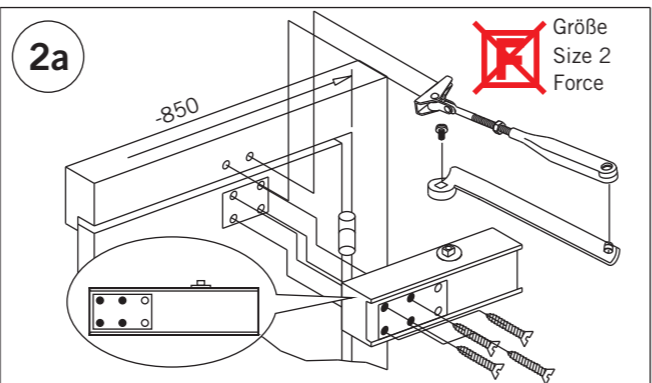
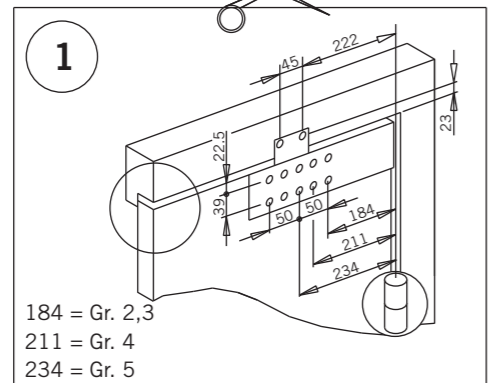
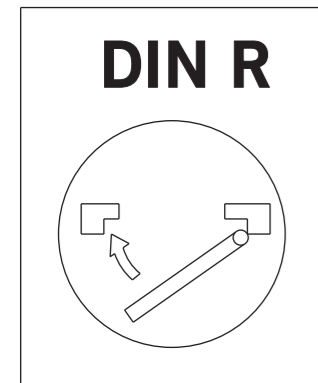

© Technische Änderungen vorbehalten! / MA-BS TS-11 F / MTS00072 / Index: g

Leistungserklärung nach Verordnung (EU) Nr. 305/2011 finden Sie unter <http://www.eco-schulte.de/leistungserklaerungen>
Declaration of performance according to Regulation (EU) No. 305/2011 see <http://www.eco-schulte.de/declarationofperformance>
Déclaration des performances conformément au règlement (UE) N° 305/2011 voir <http://www.eco-schulte.de/declarationdesperformances>